



Модель FB

-
-
-

ДВУХСТУПЕНЧАТЫЕ
РЕГУЛЯТОРЫ ДАВЛЕНИЯ
ПРЯМОГО ДЕЙСТВИЯ
ДЛЯ НИЗКОГО/СРЕДНЕГО
ДАВЛЕНИЯ

*DOUBLE STAGE
LOW-MEDIUM
PRESSURE SELF-DRIVEN
REGULATORS*



 Pietro
Fiorentini®



АВИТОН





ДВУХСТУПЕНЧАТЫЕ РЕГУЛЯТОРЫ ДАВЛЕНИЯ ПРЯМОГО
ДЕЙСТВИЯ ДЛЯ НИЗКОГО/СРЕДНЕГО ДАВЛЕНИЯ
DOUBLE STAGE LOW-MEDIUM PRESSURE SELF-DRIVEN
REGULATORS

Модель FB



1
FB В СТАНДАРТНОМ ИСПОЛНЕНИИ С ИЗМЕРИТЕЛЬНЫМ НАКОНЕЧНИКОМ
НА ВХОДЕ
FB STD WITH INLET TEST POINT



2
FB С 2 ВЫХОДНЫМИ СОЕДИНЕНИЯМИ
FB WITH 2 OUTLET CONNECTIONS



3. ИЗМЕРИТЕЛЬНЫЙ НАКОНЕЧНИК
ТИПА PETERSON
INLET TEST POINT TYPE PETERSON
4. ИЗМЕРИТЕЛЬНЫЙ НАКОНЕЧНИК
ТИПА Ø7,7X0,794
INLET TEST POINT TYPE Ø 7.7X0.794
5. ИЗМЕРИТЕЛЬНЫЙ НАКОНЕЧНИК НА
ВЫХОДЕ
OUTLET TEST POINT
6. УСТОЙЧИВАЯ К РАЗРУШЕНИЮ
ЗАГЛУШКА
INVIOLEABLE PLUG



7
FB В СТАНДАРТНОМ ИСПОЛНЕНИИ С ИЗМЕРИТЕЛЬНЫМ НАКОНЕЧНИКОМ
НА ВЫХОДЕ
FB STD WITH OUTLET TEST POINT

МАТЕРИАЛЫ / MATERIALS
КОРПУС / BODY - КРЫШКИ / COVERS
ZAMA 3 UNI EN 1774 / АЛЮМИНИЙ EN AB46100

ОБРАБОТКА НАРУЖНЫХ ПОВЕРХНОСТЕЙ / EXTERNAL TREATMENTS
КОРПУС / BODY + КРЫШКИ / COVERS
ПЕСКОСТРУЙНАЯ ОБРАБОТКА (ПО ЗАПРОСУ)
SANDBLASTING UPON REQUEST
НАПЫЛЕНИЕ ПОЛИУРЕТАНОВОГО ПОКРЫТИЯ ИЛИ ПОКРЫТИЕ
ЦИНКОВЫМИ БЕЛИЛАМИ
DUST POLYURETHANE COATING THE/OR WHITE ZINC COATED





ДВУХСТУПЕНЧАТЫЕ РЕГУЛЯТОРЫ ДАВЛЕНИЯ ПРЯМОГО
ДЕЙСТВИЯ ДЛЯ НИЗКОГО/СРЕДНЕГО ДАВЛЕНИЯ
DOUBLE STAGE LOW-MEDIUM PRESSURE SELF-DRIVEN
REGULATORS

Модель FB 6...FBS

СТАНДАРТНОЕ ИСПОЛНЕНИЕ (STANDARD)



Рис. А

- ДАВЛЕНИЕ НА ВХОДЕ
INLET PRESSURE
- ПРОМЕЖУТОЧНОЕ ДАВЛЕНИЕ
INTERMEDIATE PRESSURE
- ДАВЛЕНИЕ НА ВЫХОДЕ
OUTLET PRESSURE

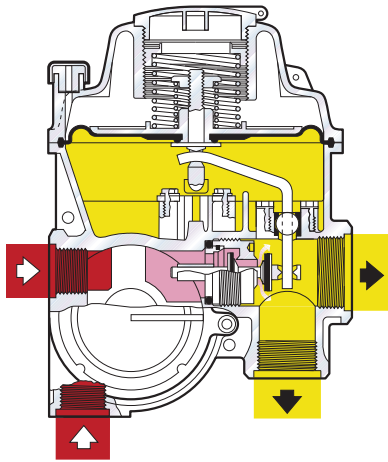

Рис. В

ГАБАРИТНЫЕ РАЗМЕРЫ - OVERALL DIMENSIONS

Рис. С

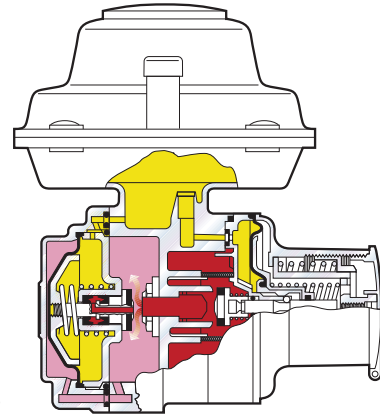

Рис. D



ДЛЯ ПОЛУЧЕНИЯ ИНФОРМАЦИИ О РАЗМЕРАХ А-В-С-D
ОБРАТИТЕСЬ к страницам 28-29-30-31
FOR DIMENSION A-B-C-D SEE pag.28-29-30-31

Wd

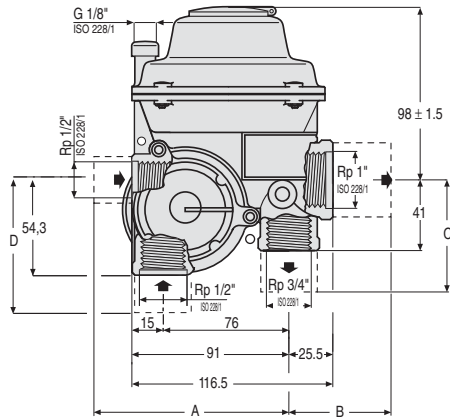
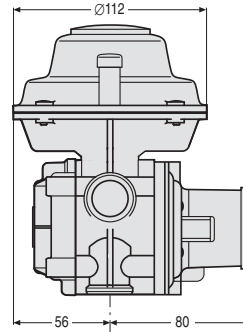
КОД / COD.	Диапазон (мбар) RANGE (mbar)
644.70184	13÷18
644.70110	18÷25
644.70111	25÷40
644.70112	40÷55
644.70113	55÷80
644.70114	80÷115
644.70115	115÷180

Таблица 1

Wdo

КОД / COD.	Диапазон (мбар) / RANGE (mbar)
644.70197	35÷50
644.70198	50÷70
644.70199	70÷100
644.70200	100÷160
644.70113	160÷220
644.70201	220÷300

Таблица 2

Wdu

КОД / COD.	Диапазон (мбар) / RANGE (mbar)
644.70120	8÷21
644.70121	21÷35
644.70122	35÷55
644.70202	55÷80

Таблица 3

РАЗНИЦА МЕЖДУ РАБОЧИМ ДАВЛЕНИЕМ РЕДУКЦИОННОГО
КЛАПАНА И НОМИНАЛЬНЫМ ДАВЛЕНИЕМ НА ВЫХОДЕ (Pd)
DIFFERENTIAL RELIEF VALVE OPERATING PRESSURE WITH
REFERENCE TO THE NOMINAL OUTLET PRESSURE (Pd)

Редукционный клапан / Relief Valve

КОД / COD.	Диапазон (мбар) / RANGE (mbar)
644.70213.00	7÷11
644.70029.00	11÷20
644.70027.00	20÷50
644.70162.00	50÷120

Таблица 4





Модель FB 6...FBS



ОПИСАНИЕ

Серия FB двухступенчатых регуляторов прямого действия с пружиной широко используется как в гражданских, так и в промышленных установках, работающих на природном газе, сжиженном углеводородном газе и других некоррозионных газах.

Регуляторы спроектированы для их установки либо напрямую на счетчике газа, либо для их установки в общую систему трубопровода.

Регуляторы могут быть установлены в любом положении при условии их защиты от неблагоприятных погодных условий.

Если регулятор устанавливается в закрытом помещении, внутренний редукционный клапан может быть выведен наружу.

Простая процедура установки.

Регуляторы выпускаются в соответствии с UNI 8827.

INTRODUCTION

The FB series of two stage self-driven spring loaded regulators are widely used in both civil and industrial installations using Natural Gas, LPG and other non corrosive gases.

They are designed for direct installation to a gas meter and for use in general pipeline work.

They can be mounted in any position provided they are protected from weather.

Where the installation is in an enclosed area, the internal relief vent can be piped to outside.

Simple installation procedure.

The regulators are manufactured according to UNI 8827.

ОСНОВНЫЕ ХАРАКТЕРИСТИКИ

Модель	Номинальный расход Qn	Давление на входе MIN Pu мин.бар (Psi)
FB 6	6 нм³/ч – 211 куб. футов/час	Pd + 0,15 – (2,2)
FB 7	7 кг/ч – 15,4 фунтов/ч	Pd + 0,15 – (2,2)
FB 10	10 нм³/ч – 353 куб. футов/час	Pd + 0,2 – (2,9)
FB 12	12 кг/ч – 26,4 фунтов/ч	Pd + 0,2 – (2,9)
FB 25	25 нм³/ч – 882,8 куб. футов/час	Pd + 0,3 – (4,3)
FB 30	30 кг/ч – 66 фунтов/ч	Pd + 0,3 – (4,3)
FB 35	35 нм³/ч – 1230,8 куб. футов/час	Pd + 0,3 – (4,3)
FB 42	42 кг/ч – 92,4 фунтов/ч	Pd + 0,3 – (4,3)
FBS	40 нм³/ч – 1412,5 куб. футов/час	Pd + 0,4 – (5,8)
FBS	48 кг/ч – 105,8 фунтов/ч	Pd + 0,4 – (5,8)
FBS	50 нм³/ч – 1765,7 куб. футов/час	Pd + 0,5 – (7,2)
FBS	60 кг/ч – 132,2 фунтов/ч	Pd + 0,5 – (7,2)

MAIN FEATURES

Model	Nominal flow rate Qn	Inlet pressure MIN Pu min bar (Psi)
FB 6	6 Stm³/h - 211 cf/h	Pd + 0.15 - (2.2)
FB 7	7 Kg/h - 15.4 Lb/h	Pd + 0.15 - (2.2)
FB 10	10 Stm³/h - 353 cf/h	Pd + 0.2 - (2.9)
FB 12	12 Kg/h - 26.4 Lb/h	Pd + 0.2 - (2.9)
FB 25	25 Stm³/h - 882.8 cf/h	Pd + 0.3 - (4.3)
FB 30	30 Kg/h - 66 Lb/h	Pd + 0.3 - (4.3)
FBS35	35 Stm³/h - 1230.8 cf/h	Pd + 0.3 - (4.3)
FBS42	42 Kg/h - 92.4 Lb/h	Pd + 0.3 - (4.3)
FBS	40 Stm³/h - 1412.5 cf/h	Pd + 0.4 - (5.8)
FBS	48 Kg/h - 105.8 Lb/h	Pd + 0.4 - (5.8)
FBS	50 Stm³/h - 1765.7 cf/h	Pd + 0.5 - (7.2)
FBS	60 Kg/h - 132.2 Lb/h	Pd + 0.5 - (7.2)

- Диапазон давления на входе bpu: 0,15÷8,6 бар – bpu: 2,2÷72,5 Psi
- Максимальное разрешенное давление PS 8,6 бар – PS 124,7 Psi
- Диапазон выходного давления:
Wd: 13÷180 мбар – Wd: 5,2÷72,3" wc
- Задаваемый диапазон устройства отключения
Wd OPSO 35÷300 мбар – Wd OPSO: 14÷120,5" wc
Wd UPSO 8÷80 мбар – Wd UPSO: 3,2÷32,1" wc
- Класс точности:
AC 5/10/15/20%
- Класс давления закрытия:
SG 25% max
- Класс температуры:
2 (-20°C + 60°C) - (-68°F + 140°F)
- Время срабатывания: менее 3 сек.

- Inlet pressure range: bpu 0.15÷8.6 bar - bpu 2.2÷72.5 Psi
- Max allowable pressure: PS 8.6 bar - PS 124.7 Psi
- Outlet pressure range:
Wd: 13÷180 mbar - Wd: 5.2÷72.3" wc
- Over pressure shut - off setting range:
Wd OPSO: 35÷300 mbar - Wd OPSO: 14÷120.5" wc
Wd UPSO: 8÷80 mbar - Wd UPSO: 3.2÷32.1" wc
- Accuracy class:
AC 5/10/15/20%
- Lock up pressure class:
SG 25% Max
- Temperature class:
2 (-20°C +60°C) - (-68°F +140°F)
- Response time: lower than 3 sec.

УСТРОЙСТВА ОБЕСПЕЧЕНИЯ БЕЗОПАСНОСТИ И АКССУАРЫ

Встроенный 100µm фильтр на входе, площадью 500 мм2 (0,775 кв. дюймов)
Устройство отключения при избыточном давлении (OPSO)
Устройство отключения при недостаточном давлении (UPSO).
Выпускной клапан
Аварийное устройство отключения при недостаточной подаче газа (UPSO)
Сброс параметров устройства отключения только в ручном режиме
Редукционный клапан

ПО ЗАПРОСУ

Измерительные наконечники на входе и выходе
С входным клапаном (без OPSO)
Без OPSO (без UPSO)

SAFETY DEVICES AND ACCESSORIES

Built-in 100 µm inlet filter with an area of 500 mm2 (0.775 inch2).
Over pressure shut-off device (OPSO).
Under pressure shut-off device (UPSO).
Excess flow valve.
Safety shut-off device for lack of feeding (UPSO).
Manual reset of safety shutoff device only.
Relief valve.
UPON REQUEST
Inlet and outlet pressure test point.
With inlet valve - (without OPSO).
Without OPSO - (without UPSO).

Azote flow rate: multiply the value in the table Stm³/h G.N. x 0.789

Значение расхода азота: умножьте значение из таблицы Нм³/ч П.Г. на 0,789





ДВУХСТУПЕНЧАТЫЕ РЕГУЛЯТОРЫ ДАВЛЕНИЯ ПРЯМОГО
ДЕЙСТВИЯ ДЛЯ НИЗКОГО/СРЕДНЕГО ДАВЛЕНИЯ
DOUBLE STAGE LOW-MEDIUM PRESSURE SELF-DRIVEN
REGULATORS

Модель FB 6...FBS

ВХОД - INLET

Рис. 1
070.00260.00



Рис. 2
070.00190.00



Рис. 3
070.00220.00

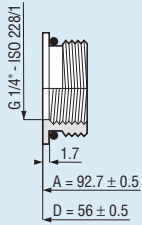

Рис. 4
070.00120.00

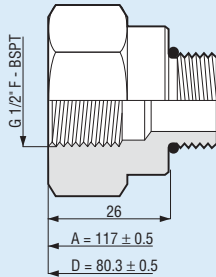

Рис. 5
070.00150.00

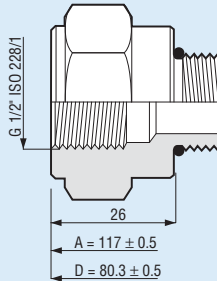

Рис. 6
063.00120.00

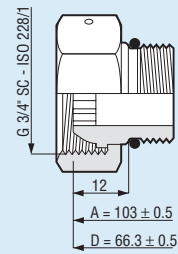

Рис. 7
070.00170.00

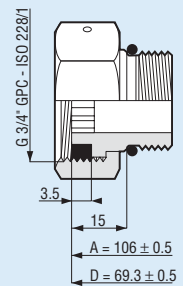

Рис. 8
070.00140.00

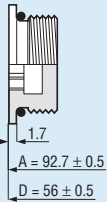

Рис. 9
070.00200.00

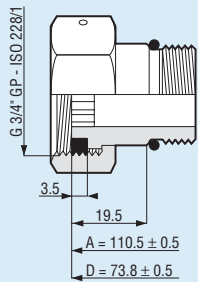

Рис. 10
070.00180.00

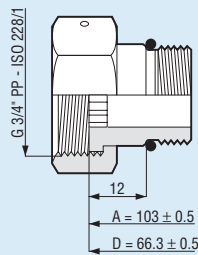

Рис. 11
070.00130.00

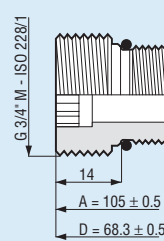

Рис. 12
070.00230.00

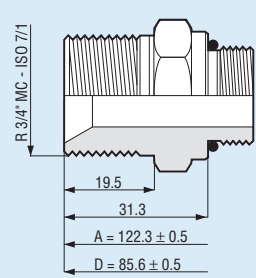

Рис. 13
070.00290.00

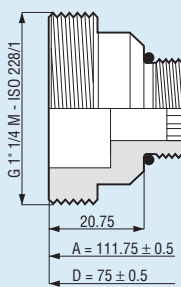

Рис. 14
070.00160.00

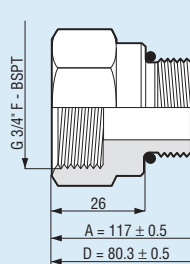

Рис. 15
070.00100.00

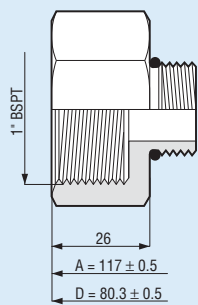

Рис. 16
633.50169.ZB

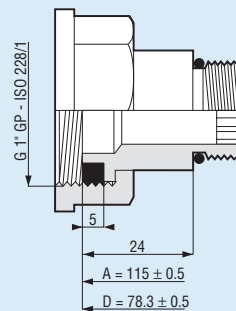

Рис. 17
070.00120.00

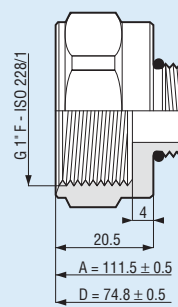

Рис. 18
633.50189.ZB

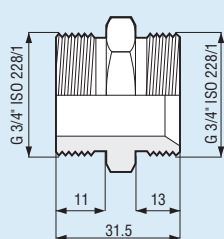

Рис. 19
070.00120.00

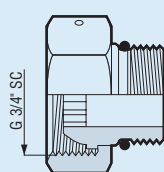

VT = с термодопуском
with Thermic Valve



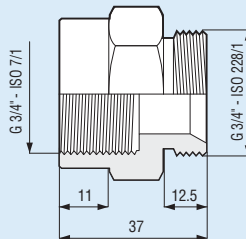
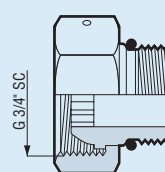

ФИТИНГИ - FITTINGS



РЕГУЛЯТОР МОЖНО ЗАКАЗАТЬ
КАК ФИТИНГАМИ, ТАК И БЕЗ НИХ.
THE REGULATOR MAY BE
ORDERED WITH OR WITHOUT
FITTINGS



Рис. 20
070.10020.01



Рис. 21
070.10025.01

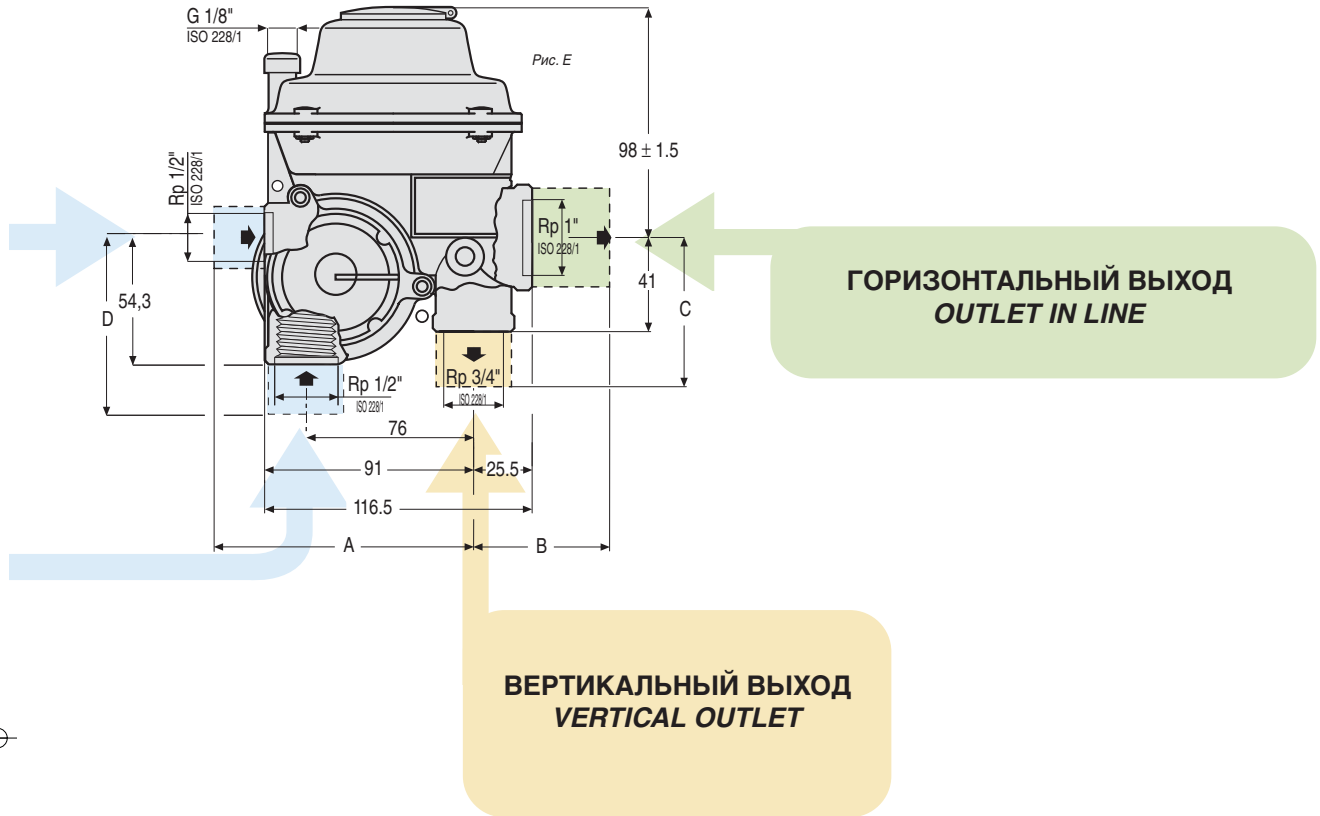

Рис. 22
070.10068.01



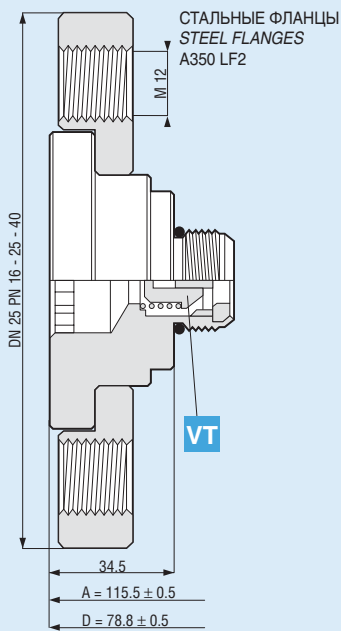

ДВУХСТУПЕНЧАТЫЕ РЕГУЛЯТОРЫ ДАВЛЕНИЯ ПРЯМОГО
ДЕЙСТВИЯ ДЛЯ НИЗКОГО/СРЕДНЕГО ДАВЛЕНИЯ
DOUBLE STAGE LOW-MEDIUM PRESSURE SELF-DRIVEN
REGULATORS

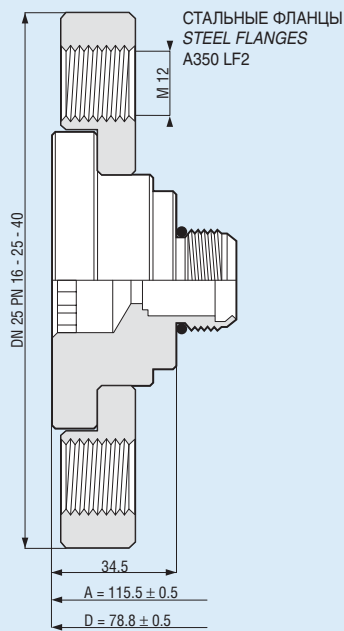
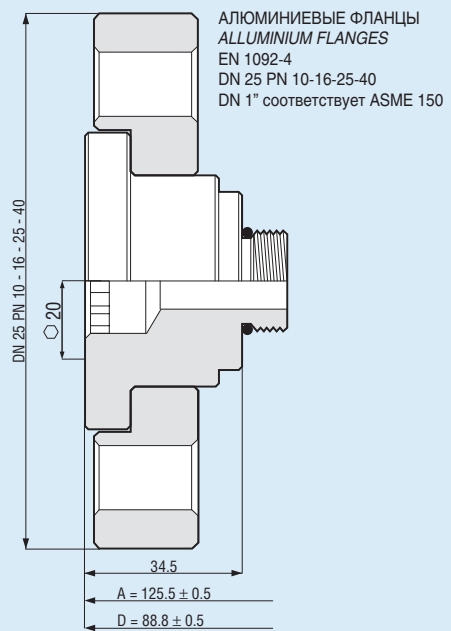
Модель FB 6...FBS

РЕГУЛЯТОР МОЖНО ЗАКАЗАТЬ
КАК ФИТИНГАМИ, ТАК И БЕЗ НИХ.
THE REGULATOR MAY BE
ORDERED WITH OR WITHOUT
FITTINGS

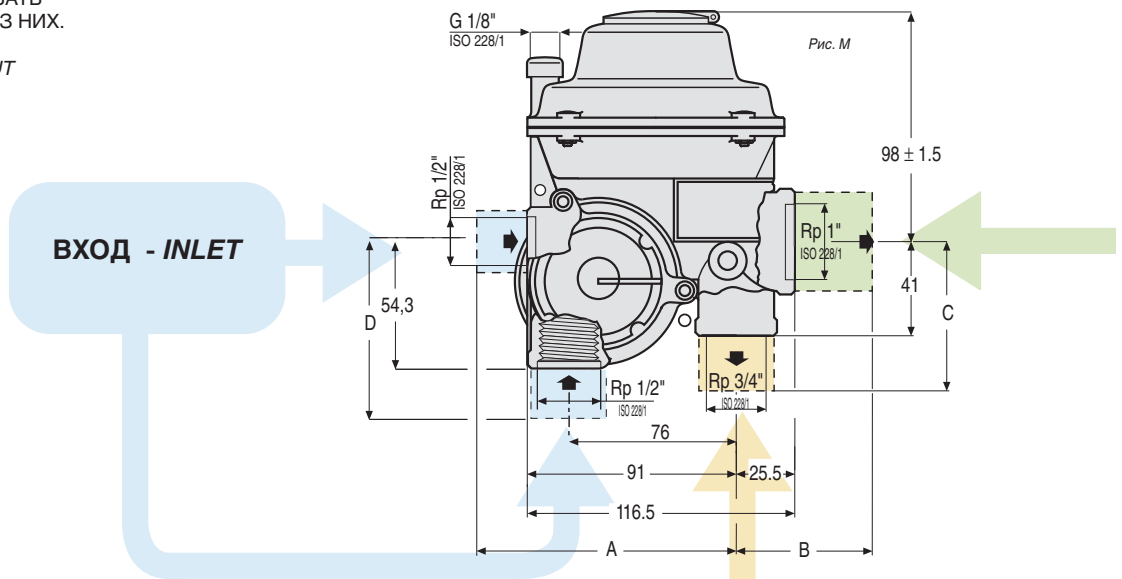

ВЕРТИКАЛЬНЫЙ ВЫХОД - VERTICAL OUTLET

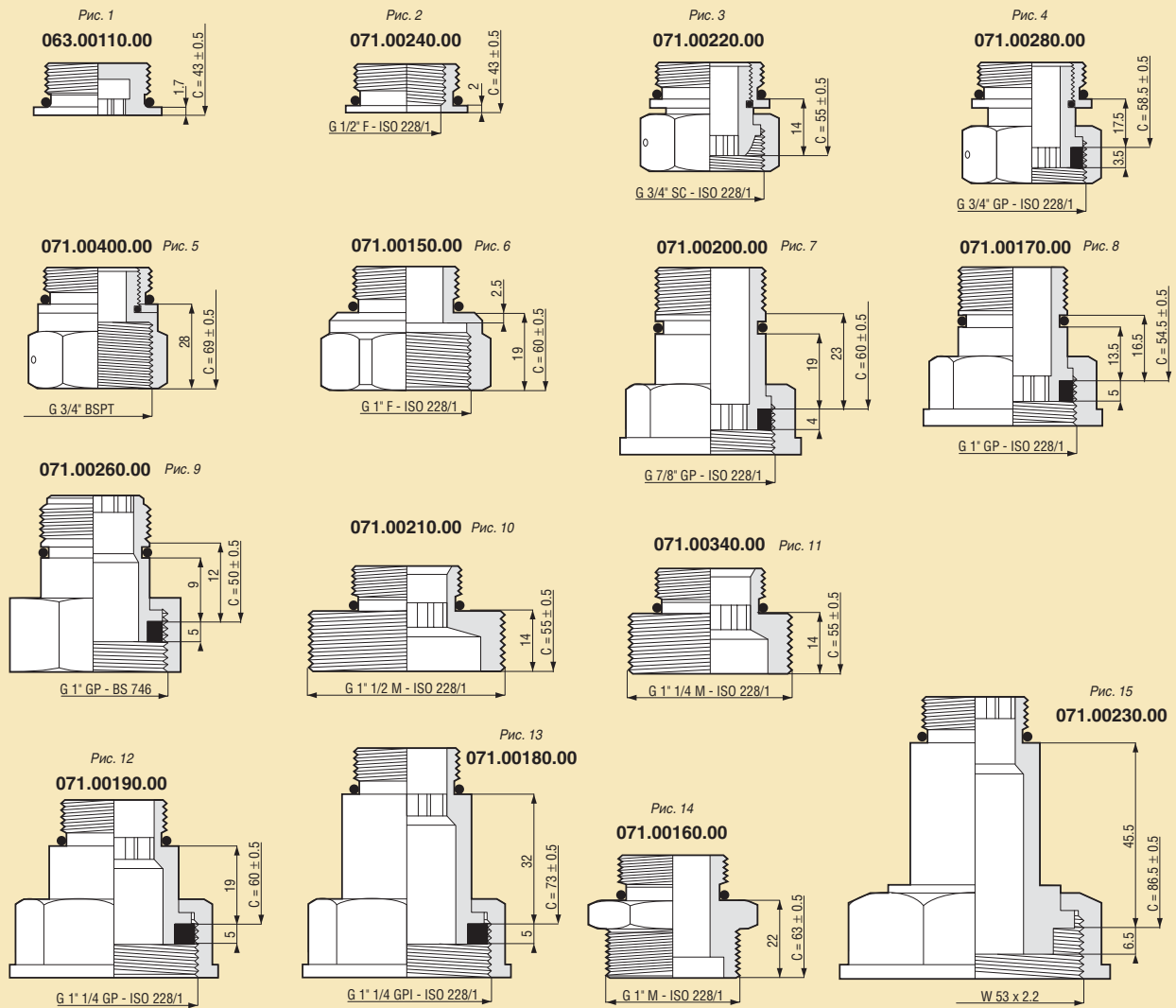



ФИТИНГИ - FITTINGS



ГОРИЗОНТАЛЬНЫЙ ВЫХОД - OUTLET IN LINE

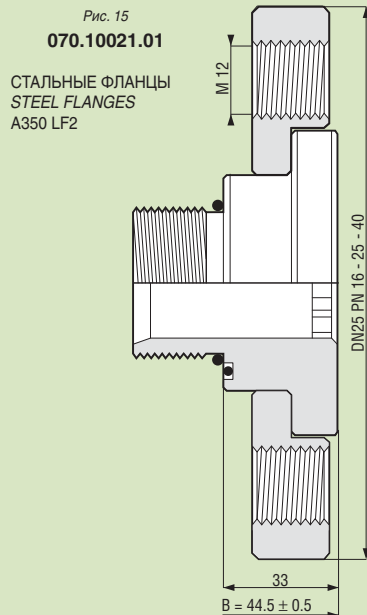
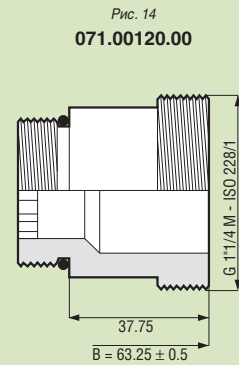
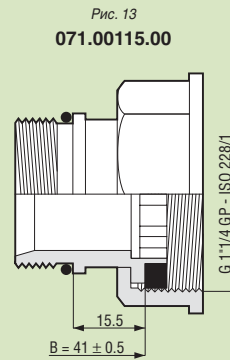
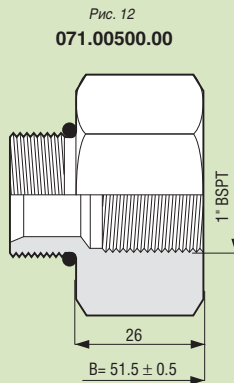
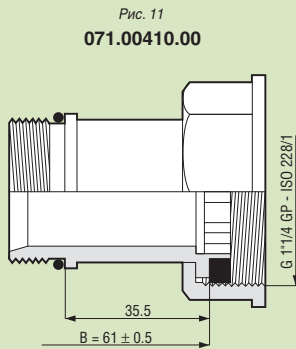
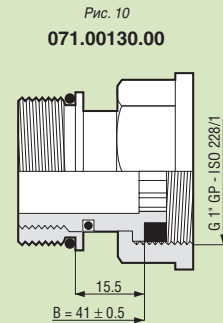
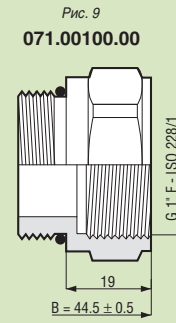
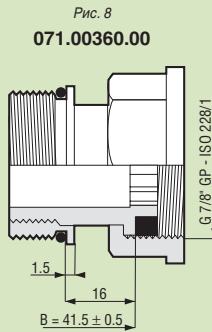
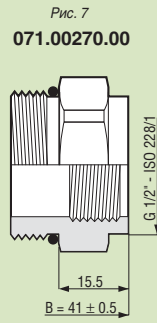
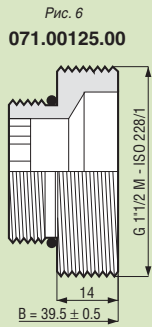
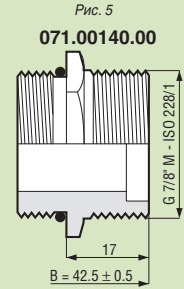
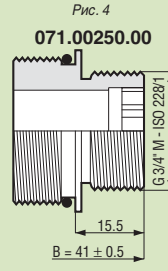
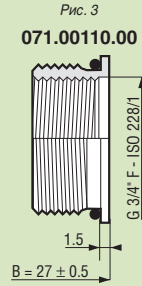
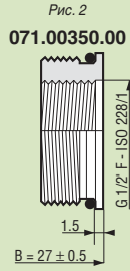
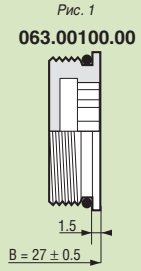

АЛЮМИНИЕВЫЕ ФЛАНЦЫ
ALLUMINIUM FLANGES
EN 1092-4
DN 25 PN 10-16-25-40
DN 1" соответствует ASME 150





ТАБЛИЦА ОБОЗНАЧЕНИЙ
T-00810 Модель FB6...FBS

LEGENDA	
①	Sigla prodotto
②	Modello Regolatore
③	Pressione d'ingresso MIN
④	Pressione d'ingresso MAX
⑤	Accessori
⑥	Targhettatura e imballo
⑦ ⑧	Connessioni entrata/uscita
⑨ ⑩	Tarature
⑪	Versione
STD	Standard
SC	Sfero-Conico
GP	Girello Piano
GPC	Girello Piano Corto
GPI	Girello Piano IT
PP	Girello Piatto
SS	Valvola di sfioro Si
SN	Valvola di sfioro No
F	Femmina
M	Maschio
MC	Maschio conico

		MOD.	Portata	MOD.	Portata	
		GN	(m ³ /h)	GPL	(Kg/h)	
	FB L	A	FB 6L	6	FB 7L	7
		C	FB 10L	10	FB 12L	12
		E	FB 25L	25	FB 30L	30
		J	FBS-L	35	FBS-L	42
		G	FBS-L	40	FBS-L	48
		I	FBS-L	50	FBS-L	60
	FB S	B	FB 6S	6	FB 7S	7
		D	FB 10S	10	FB 12S	12
		F	FB 25S	25	FB 30S	30
		K	FBS-S	35	FBS-S	42
		H	FBS-S	40	FBS-S	48
		L	FBS-S	50	FBS-S	60
	FB T	M	FB 6T	6	FB 7T	7
		P	FB 10T	10	FB 12T	12
		S	FB 25T	25	FB 30T	30
		Q	FBS-T	35	FBS-T	42
		U	FBS-T	40	FBS-T	48
		W	FBS-T	50	FBS-T	60
	FB U	N	FB 6U	6	FB 7U	7
		R	FB 10U	10	FB 12U	12
		T	FB 25U	25	FB 30U	30
		Y	FBS-U	35	FBS-U	42
		V	FBS-U	40	FBS-U	48
		X	FBS-U	50	FBS-U	60
	FB Q	Z	FB 6Q	6	FB 7Q	7
		1	FB 10Q	10	FB 12Q	12
		2	FB 25Q	25	FB 30Q	30
		3	FBS-Q	35	FBS-Q	42
		4	FBS-Q	40	FBS-Q	48
		5	FBS-Q	50	FBS-Q	60

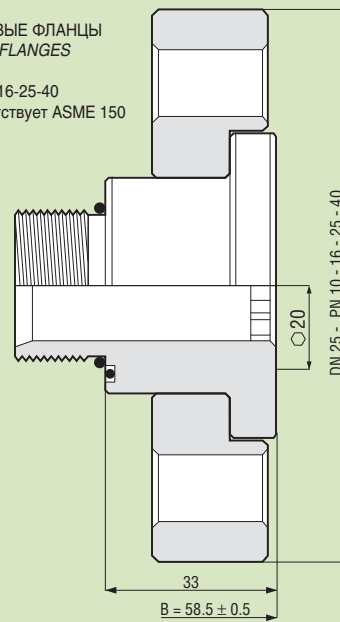
Pu-MIN (bar)	
A	0.1
B	0.2
C	0.3
D	0.4
E	0.5
F	0.6
G	0.7
H	0.8
I	0.9
J	1
K	1.5
L	2
1	2,5
M	3
2	3,5
N	4
3	4,5
P	5
Q	6
R	7
S	8,6

Pu-MAX (bar)	
A	0.1
B	0.2
C	0.3
D	0.4
E	0.5
F	0.6
G	0.7
H	0.8
I	0.9
J	1
K	1.5
L	2
1	2,5
M	3
2	3,5
N	4
3	4,5
P	5
Q	6
R	7
S	8,6

VERSIONE	
A	STANDARD G.N.
B	X FLUIDO GPL
C	X FLUIDO OSSIGENO
D	A + CON PIOMBATURA
E	A + SFIATI SUPPLEMENTARI + X + D
F	A + PRESA MANOMETRICA ESTERNA IN USCITA
G	A + TAPPO CHIUSURA REG. INVIOLEABILE (DODECAGONALE)
H	•
I	•
J	•
K	•
L	A + VERSIONE INTERRATA (COMPONENTI VERNICIATI)
M	•
N	B + VERSIONE INTERRATA (COMPONENTI VERNICIATI)
P	•
Q	•
R	B + PRESA MANOMETRICA ESTERNA IN USCITA
S	A + L + F
T	•
U	A + SFIATI SUPPLEM. + F + X (PIPELINE)
V	•
W	•
X	A + VERSIONE VERNICIATA
Y	•
Z	•
1	U + PRESA MANOMETRICA ESTERNA IN ENTRATA
2	•
3	A + D + X
4	A + X + SFIATI SUPPLEMENTARI
5	***
6	A + F + G
7	A + F + MANOMETRO IN ENTRATA
8	•
9	•
S	VERSIONE PERSONALIZZATA CLIENTE

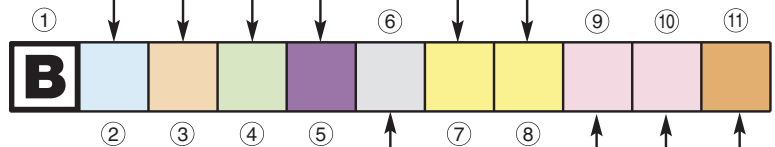

	TARGHETTATURA			IMBALLO
	LINGUA	LOGO	U.M.	
A	ITALIANO / INGLESE	PERSONALIZZATO CLIENTE	MBAR	SCATOLA SINGOLA
B	SPAGNOLO	P. FIORENTINI/K	MBAR	
C	ITALIANO / INGLESE	PIETRO FIORENTINI	MBAR	
D	•	•	•	
E	ITALIANO/INGLESE	PIETRO FIORENTINI	KPA	SCATOLA SINGOLA + CONTENITORE DA 10 PZ.
F	POLACCO	PIETRO FIORENTINI FM	KPA	
G	GRECO	PIETRO FIORENTINI	MBAR	
W	ITALIANO / INGLESE	PIETRO FIORENTINI	mmH2o	
X	INGLESE	FIORENTINI MINIREG	mmH2o	
3	REP. CECA	PIETRO FIORENTINI	KPA	

H	ITALIANO / INGLESE	PERSONALIZZATO CLIENTE	MBAR	SCATOLA SINGOLA + CONTENITORE DA 10 PZ.
I	SPAGNOLO	P. FIORENTINI/K	MBAR	
J	ITALIANO / INGLESE	PIETRO FIORENTINI	MBAR	
K	•	•	•	
L	ITALIANO / INGLESE	PIETRO FIORENTINI	KPA	SCATOLA SINGOLA + CONTENITORE AD ALVEARE DA 10 PZ.
M	POLACCO	PIETRO FIORENTINI FM	KPA	
N	GRECO	PIETRO FIORENTINI	MBAR	
Y	ITALIANO / INGLESE	PIETRO FIORENTINI	mmH2o	
Z	INGLESE	FIORENTINI MINIREG	mmH2o	
4	REP. CECA	PIETRO FIORENTINI	KPA	

P	ITALIANO / INGLESE	PERSONALIZZATO CLIENTE	MBAR	SENZA SCATOLA SINGOLA + CONTENITORE AD ALVEARE DA 10 PZ.
Q	SPAGNOLO	P. FIORENTINI/K	MBAR	
R	ITALIANO / INGLESE	PIETRO FIORENTINI	MBAR	
S	•	•	•	
T	ITALIANO / INGLESE	PIETRO FIORENTINI	KPA	SENZA SCATOLA SINGOLA + CONTENITORE AD ALVEARE DA 10 PZ.
U	POLACCO	PIETRO FIORENTINI FM	KPA	
V	GRECO	PIETRO FIORENTINI	MBAR	
1	ITALIANO / INGLESE	PIETRO FIORENTINI	mmH2o	
2	INGLESE	FIORENTINI MINIREG	mmH2o	
5	REP. CECA	PIETRO FIORENTINI	KPA	





	BLOCCO	SFIORO	V.E.F.
A	MAX	SS	VEFN
B	MAX	SS	VEFN
C			
D			
E	MAX / MIN	SS	VEFS
F			
G	MAX / MIN	SN	VEFS

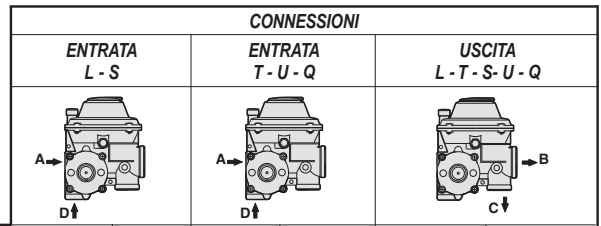

L/T	S/U	CONNESSIONI	CONNESSIONI					
			ENTRATA L-S		ENTRATA T-U-Q		USCITA L-T-S-U-Q	
			A	D	A	D	B	C
0 0		1"Fx1" F-K	070.00100.00	CHIUSO	CHIUSO	070.00100.00	071.00100.00	063.00110.00
0 1		1"GPx1"1/4 GP-K	070.00160.00	CHIUSO	CHIUSO	070.00160.00	071.00115.00	063.00110.00
0 2		3/4"GPx7/8" M-K	070.00170.00	CHIUSO	CHIUSO	070.00170.00	071.00140.00	063.00110.00
0 3		1"GPx1"1/2 M-K	070.00160.00	CHIUSO	CHIUSO	070.00160.00	071.00125.00	063.00110.00
0 4		1"GPx1" GP	070.00160.00	CHIUSO	CHIUSO	070.00160.00	071.00130.00	063.00110.00
0 5		1"GPx3/4" F	070.00160.00	CHIUSO	CHIUSO	070.00160.00	071.00110.00	063.00110.00
0 6		1"1/4Mx1"1/4 M	070.00130.00	CHIUSO	CHIUSO	070.00130.00	071.00120.00	063.00110.00
0 7		3/4"SCx1" F	070.00120.00	CHIUSO	CHIUSO	070.00120.00	071.00100.00	063.00110.00
0 8		3/4"GPx1"1/4 GP-k	070.00170.00	CHIUSO	CHIUSO	070.00170.00	071.00115.00	063.00110.00
0 9		3/4"SCx1"1/4 GP	070.00120.00	CHIUSO	CHIUSO	070.00120.00	071.00115.00	063.00110.00
1 0		3/4"GPCx1"1/4 GP-k	070.00150.00	CHIUSO	CHIUSO	070.00150.00	071.00115.00	063.00110.00
1 1		1/2"Fx1"2" F	Corpo (1/2")	CHIUSO	CHIUSO	Corpo (1/2")	071.00110.00	063.00110.00
1 2		R 3/4"MCx1"1/4 GP	070.00180.00	CHIUSO	CHIUSO	070.00180.00	071.00115.00	063.00110.00
1 3		3/4"SCx1" GP	070.00120.00	CHIUSO	CHIUSO	070.00120.00	071.00130.00	063.00110.00
1 4		3/4"GPCx1" GP-K	070.00150.00	CHIUSO	CHIUSO	070.00150.00	071.00130.00	063.00110.00
1 5		3/4"MCx3/4" M	070.00200.00	CHIUSO	CHIUSO	070.00200.00	071.00250.00	063.00110.00
1 6		1/2 Fx1"1/4 GP	Corpo (1/2")	CHIUSO	CHIUSO	Corpo (1/2")	071.00115.00	063.00110.00
1 7		3/4"GPCx1" F-K	070.00150.00	CHIUSO	CHIUSO	070.00150.00	071.00100.00	063.00110.00
1 8		1/2"Fx1"2" F	070.00220.00	CHIUSO	CHIUSO	070.00220.00	071.00350.00	063.00110.00
1 9		3/4"GPCx1" F	070.00150.00	CHIUSO	CHIUSO	070.00150.00	Corpo (1")	063.00110.00
2 0		3/4"MCx1"1/4 M	070.00180.00	CHIUSO	CHIUSO	070.00180.00	071.00120.00	063.00110.00
2 2		3/4"SCx1" F	070.00120.00	CHIUSO	CHIUSO	070.00120.00	Corpo (1")	063.00110.00
2 3		3/4"SCx7/8" GP	070.00120.00	CHIUSO	CHIUSO	070.00120.00	071.00360.00	063.00110.00
2 4		DnE/U 25-PN16-25-40	070.10025.01	CHIUSO	CHIUSO	070.10025.01	070.10021.01	063.00110.00
9 4		DnE/U 25-PN40-ASME	070.10068.01	CHIUSO	CHIUSO	070.10068.01	070.10065.01	063.00110.00
2 5		1/2"Fx1" F	Corpo (1/2")	CHIUSO	CHIUSO	Corpo (1/2")	071.00100.00	063.00110.00
2 6		3/4"PPx1" F	070.00140.00	CHIUSO	CHIUSO	070.00140.00	071.00100.00	063.00110.00
2 7		3/4"GPx1" GP	070.00170.00	CHIUSO	CHIUSO	070.00170.00	071.00130.00	063.00110.00
2 8		3/4"SCx1"1/4 GP L.35.5	070.00120.00	CHIUSO	CHIUSO	070.00120.00	071.00250.00	063.00110.00
A 1		3/4"SCx3/4" M	070.00120.00	CHIUSO	CHIUSO	070.00120.01	070.00250.00	063.00110.00
A 2		1/2"Fx1"2" F	Corpo (1/2")	CHIUSO	CHIUSO	Corpo (1/2")	Corpo (1")	063.00110.00
2 9		1" F 1"1/2 M	070.00100.00	CHIUSO	CHIUSO	070.00100.00	071.00125.00	063.00110.00
A 4		1" BSPTx 1" BSPT	070.00290.00	CHIUSO	CHIUSO	070.00290.00	071.00500.00	063.00110.00
A 5								
A 6								
A 7								
A 8		3/4"SCx1"1/4 GP L.35.5	070.00120.00	CHIUSO	CHIUSO	070.00120.00	071.00410.00	063.00110.00
C 5		1/2"NPTx3/4"NPT	070.00330.00	CHIUSO	CHIUSO	070.00330.00	071.00530.00	063.00110.00
2 1		3/4"GPCx7/8" M	070.00150.00	CHIUSO	CHIUSO	070.00150.00	071.00140.00	063.00110.00
A 9		1"GPCx1" F	070.00160.00	CHIUSO	CHIUSO	070.00160.00	071.00100.00	063.00110.00
3 0		3/4"SCx1" GP	070.00120.00	CHIUSO	CHIUSO	070.00120.00	063.00100.00	071.00170.00
3 1		3/4"GPx1" M-K	070.00170.00	CHIUSO	CHIUSO	070.00170.00	063.00100.00	071.00160.00
3 2		3/4"GPCx1" GP	070.00150.00	CHIUSO	CHIUSO	070.00150.00	063.00100.00	071.00170.00
3 3		3/4"SCx3/4" GP	070.00120.00	CHIUSO	CHIUSO	070.00120.00	063.00100.00	071.00280.00
3 4		3/4"SCx3/4" SC	070.00120.00	CHIUSO	CHIUSO	070.00120.00	063.00100.00	071.00220.00
3 5		R 3/4"MCx53p2.2GP	070.00180.00	CHIUSO	CHIUSO	070.00180.00	063.00100.00	071.00230.00
3 6		1/2"BSTP Fx1"BS746GP	070.00190.00	CHIUSO	CHIUSO	070.00190.00	063.00100.00	071.00260.00
3 7		1/2"Fx1"1/4 GP	Corpo (1/2")	CHIUSO	CHIUSO	Corpo (1/2")	063.00100.00	071.00190.00
3 8		3/4"SCx3/4" F	070.00120.00	CHIUSO	CHIUSO	070.00120.00	063.00100.00	071.00190.00
3 9		3/4"GPx1"1/4 GP	070.00170.00	CHIUSO	CHIUSO	070.00170.00	063.00100.00	071.00190.00
4 0		1"GPx1" GP	070.00160.00	CHIUSO	CHIUSO	070.00160.00	063.00100.00	071.00170.00
4 1		3/4"GPx3/4" GP	070.00170.00	CHIUSO	CHIUSO	070.00170.00	063.00100.00	071.00280.00
4 2		3/4"SCx7/8" GP	070.00120.00	CHIUSO	CHIUSO	070.00120.00	063.00100.00	071.00200.00
4 3		1"GPx1"1/4 GPI	070.00160.00	CHIUSO	CHIUSO	070.00160.00	063.00100.00	071.00180.00
4 4		3/4"GPCx3/4" F	070.00150.00	CHIUSO	CHIUSO	070.00150.00	063.00100.00	Corpo (3/4")
4 5		3/4"GPx1"1/4 GPI	070.00170.00	CHIUSO	CHIUSO	070.00170.00	063.00100.00	071.00180.00
4 6		R 3/4"MCx3/4" F	070.00180.00	CHIUSO	CHIUSO	070.00180.00	063.00100.00	Corpo (3/4")
6 0		3/4"SCx1"1/4 GP	070.00120.00	CHIUSO	CHIUSO	070.00120.00	063.00100.00	071.00190.00
6 1		3/4"SCx1"1/4 GPI	070.00120.00	CHIUSO	CHIUSO	070.00120.00	063.00100.00	071.00180.00
6 2		1"GPx1"1/2 M-K	070.00160.00	CHIUSO	CHIUSO	070.00160.00	063.00100.00	071.00210.00
6 3		3/4"GPCx1"1/4 GP	070.00150.00	CHIUSO	CHIUSO	070.00150.00	063.00100.00	071.00190.00
6 4		1"Fx1" F	070.00100.00	CHIUSO	CHIUSO	070.00100.00	063.00100.00	071.00150.00
6 5		1"GPx1"1/4 GP	070.00160.00	CHIUSO	CHIUSO	070.00160.00	063.00100.00	071.00190.00
6 6		1"Fx1"1/4 GP	070.00100.00	CHIUSO	CHIUSO	070.00100.00	063.00100.00	071.00190.00

	TARATURE (mbar)				TARATURE (mmH2o)			
	Pd	Sf	Pdsu	Pdsu	Pd	Sf	Pdsu	Pdsu
A B	13	24.5	50	NO	132.5	250	510	NO
A F	15	25	35	NO	153	255	357	NO
B B	15	25	40	NO	153	255	408	NO
A G	15	35	50	NO	153	357	510	NO
A A	SENZA MOLLE							
A P	16	32	43	8	163	326	438	82
A I	18	32	43	10	183.5	326	438	102
A K	19	32	43	10	193.7	326	438	102
A H	20	27	35	10	204	275	357	102
B F	20	30	45	10	204	306	459	102
A S	20	32	42	10	204	326	428	102
A U	20	32	43	10	204	326	438	102
A T	20	33.5	50	10	204	342	510	102
A Z	20	35	45	10	204	357	459	102
B E	20	35	70	10	204	357	714	102
B D	20	50	40	10	204	510	408	102
B I	21	28	40	10	214	286	408	102
B J	21	28	38	10	214	286	388	102
B S	21	32	43	10	214	326	438	102
B X	21	35	50	10	214	357	510	102
B V	21	40	50	10	214	408	510	102
B Y	21	45	70	10	214	459	714	102
B Z	21	60	50	10	214	612	510	102
C B	21	75	50	10	214	765	510	102
C E	22	32	43	10	224	326	438	102
C L	22	32	50	10	224	326	510	102
C P	22	45	70	10	224	459	714	102
C S	22	45	110	10	224	459	1122	102
C F	22.5	32	44	10	230	326	450	102
C U	25	35	45	10	255	357	459	102
C Z	25	35	50	10	255	357	510	102
D E	25	35	55	10	255	357	561	102
C X	25	35	70	10	255	357	714	102
C V	25	40	50	10	255	408	510	102
D B	26	51	42	14	265	520	428	144
C W	27	65	55	12	275	663	561	122
D H	27	75	50	12	275	765	510	122
D A	27.5	50	70	12	280	510	714	122
D C	28	38	48	12	286	388	490	122
D I	30	40	50	15	306	408	510	153
D K	30	60	70	15	306	612	714	153
D M	30	60	80	15	357	612	816	153
D T	35	46	55	15	357	469	510	153
D V	35	60	70	15	357	612	714	153
D Y	37	55	75	15	377	561	765	153
E A	37	60	70	15	377	612	714	153
E F	39	60	50	20	409.5	612	510	204
E B	39	75	65	20	398	765	663	204
E D	39	60	80	20	398	612	816	204
E E	40	60	80	20	408	612	816	204
E M	45	75	105	20	459	765	1071	204
E Y	50	75	110	25	510	765	1122	255
E Z	50	75	150	25	510	765	1530	255
F H	50	80	120	25	510	816	1224	255
F J	50	80	130	25	510	816	1326	255
F K	55	80	125	25	561	816	1275	255
F N	55	80	140	25	561	816	1428	255
F S	60	90	120	25	612	918	1224	255
F W	70	100	130	30	714	1020	1326	306
G E	80	120	150	30	816	1224	1530	306
G M	100							



ДВУХСТУПЕНЧАТЫЕ РЕГУЛЯТОРЫ ДАВЛЕНИЯ ПРЯМОГО ДЕЙСТВИЯ ДЛЯ НИЗКОГО/СРЕДНЕГО ДАВЛЕНИЯ
DOUBLE STAGE LOW-MEDIUM PRESSURE SELF-DRIVEN REGULATORS

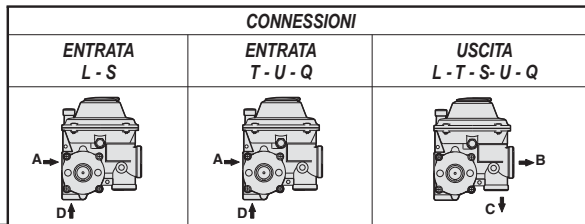

CONNESSIONI		A	D	A	D	B	C
6 7	3/4"PPx1"1/4GP	070.00140.00	CHIUSO	CHIUSO	070.00140.00	063.00100.00	071.00190.00
6 8	3/4"PPx1"1/4GPI	070.00140.00	CHIUSO	CHIUSO	070.00140.00	063.00100.00	071.00180.00
6 9	3/4"BSPTx1"BS746	070.00230.00	CHIUSO	CHIUSO	070.00230.00	063.00100.00	071.00260.00
7 0	3/4"GPCx7/8"GP	070.00150.00	CHIUSO	CHIUSO	070.00150.00	063.00100.00	071.00200.00
7 1	3/4"GPCx3/4"GP	070.00150.00	CHIUSO	CHIUSO	070.00150.00	063.00100.00	071.00280.00
7 2	1"1/4Mx1"1/4M	070.00130.00	CHIUSO	CHIUSO	070.00130.00	063.00100.00	071.00340.00
7 3	3/4"GPCx3/4"BSPT	070.00150.00	CHIUSO	CHIUSO	070.00150.00	063.00100.00	071.00400.00
7 4	1"GPx3/4"GP	070.00160.00	CHIUSO	CHIUSO	070.00160.00	063.00100.00	071.00280.00
7 5	3/4"BSPTx5/8x2.2"GP	070.00230.00	CHIUSO	CHIUSO	070.00230.00	063.00100.00	071.00230.00
7 6	1"Fx5/8x2.2 GP	070.00100.00	CHIUSO	CHIUSO	070.00100.00	063.00100.00	071.00230.00
7 7	3/4"GPx3/4"F	070.00170.00	CHIUSO	CHIUSO	070.00170.00	063.00100.00	Corpo (3/4")
7 8	3/4"PPx3/4"GP	070.00140.00	CHIUSO	CHIUSO	070.00140.00	063.00100.00	071.00280.00
7 9	3/4"SCxCAL32GP	070.00120.00	CHIUSO	CHIUSO	070.00120.00	063.00100.00	071.00510.00
8 9	1/2"Fx3/4"F			Corpo (1/2")	063.00120.00	063.00100.00	Corpo (3/4")
9 0	1/2"Fx1"F			Corpo (1/2")	063.00120.00	Corpo (1")	063.00110.00
9 1	1/2"Fx1"Fx3/4"F			Corpo (1/2")	Corpo (1/2")	Corpo (1")	Corpo (3/4")
9 2	3/4"SCxTAPPI S/L			070.00120.00	063.00120.00	063.00100.00	063.00110.00
9 3	3/4"SCx3/4"Fx1"F			070.00120.00	063.00120.00	Corpo (1")	Corpo (3/4")
2 1							
9 5	1"GPx1"GPx 1"GP			070.00160.00	063.00120.00	071.00130.00	071.00170.00
9 6	1"GPx1"GPx3/4"GP			070.00160.00	063.00120.00	071.00130.00	071.00280.00
9 7	1"GPx1"1/4GPx1"GP			070.00160.00	063.00120.00	071.00115.00	071.00170.00
9 8	1"Fx1"F +			070.00100.00	070.00100.00	063.00100.00	071.00150.00
	TAPPI DA 1"					063.00100.00	063.00100.00
9 9	1"GPx1"GP+			070.00160.00	070.00260.00	071.00130.00	063.00110.00
	PRESA MAN.+TAPPO 3/4"						
B 3	3/4"BSPTx1"BS746			063.00120.00	070.00230.00	063.00100.00	071.00260.00
B 4	3/4"BSPTx5/8p2.2			063.00120.00	070.00230.00	063.00100.00	071.00230.00
B 5	3/4"GPx1"GP			070.00170.00	063.00120.00	071.00130.00	063.00110.00
B 6	3/4"SCx3/4"GPx1"GP			063.00120.00	070.00120.00	071.00130.00	071.00280.00
B 9	3/4"GPCx1"1/4GP			070.00150.00	063.00120.00	063.00100.00	071.00190.00
C 1	3/4"SCx1"1/4GP			063.00120.00	070.00120.00	063.00100.00	071.00190.00
C 2	3/4"SCx1"1/4GP			070.00120.00	063.00120.00	063.00100.00	071.00190.00
C 3	3/4"BSPT VTx5/8p2.2GP			063.00120.00	070.00310.00	063.00100.00	071.00230.00
C 4	3/4"BSPT VTx1"BS746			063.00120.00	070.00310.00	063.00100.00	071.00260.00
C 6	1"Fx1"F			070.00100.00	063.00120.00	071.00100.00	063.00110.00
C 7	3/4"GPx1"1/4GP			063.00120.00	070.00170.00	063.00100.00	071.00190.00
C 8	1"GPx1"GP			070.00160.00	063.00120.00	071.00130.00	063.00110.00

Данная таблица представлена только для ознакомления. Для получения всех возможных вариантов см. конфигуратор FM на сайте: www.fiorenzochange.com/Servizi Fiorentini, где представлена также и английская версия.

This table is only demonstration.
 To create all allowable versions please refer to FM configurator on website: www.fiorenzochange.com/Servizi Fiorentini where you can also find english translation

Per l'ordinazione, seguire scrupolosamente quanto richiesto dalla casella 3 alla 11

- 1 Sigla identificativa del prodotto
 - 2 Modello di regolatore (da scegliere in funzione della portata richiesta)
 - 3 Pressioni di ingresso MIN
 - 4 Pressioni di ingresso MAX
 - 5 Accessori
 - 6 Targhettatura
 - 7-8 Conneessioni
 - 9-10 Tarature pressione uscita nominali regolate e dispositivi di sicurezza standard
 - 11 Versione
- N.B.:** Per eventuali versioni non previste dalla tabella, si prega di inviare una richiesta scritta descrivendo dettagliatamente le caratteristiche del prodotto.
 La Fiorentini Minireg S.p.A. si impegna a verificare la fattibilità di quanto richiesto.





РАЗМЕРЫ УПАКОВКИ
PACKAGING DIMENSIONS

Модель FB



РАЗМЕРЫ УПАКОВКИ - PACKAGING DIMENSIONS

Указатель	Кол-во единиц, шт	Размеры, см	Объем, м³	Вес, кг	Паллет макс. Д x Ш x В, см		
					Кол-во единиц, шт	Вес, кг	Объем, м³
FB6- FB10- FB25S- FBS (П.Г.)	1	14x14x19	0,004	1,4÷2	120x80x152		
FB7-FB12-FB30-FBS (С.У.Г.)	1	14x14x19	0,004	1,4÷2			
FB6-FB10-FB25S-FBS (П.Г.)	10	72x29,5x19,8	0,046	14÷20,5	250	325-450	1,46
FB7-FB12-FB30-FBS (С.У.Г.)	10	72x29,5x19,8	0,046	14÷20,5			

Целью составления настоящего документа является предоставление полезной информации разработчику систем и/или установщику. Принимая во внимание нормальную эволюцию продукта, компания FIORENTINI MINIREG S.p.A. оставляет за собой право в любое время изменить данные в отношении представленных устройств. Необходимо отметить, что фотографии и данные, содержащиеся в данном каталоге должны рассматриваться только в качестве общей информации. Для получения точных данных о характеристиках продукта необходимо обратиться в СЛУЖБУ ТЕХНИЧЕСКОЙ ПОДДЕРЖКИ. Компания FIORENTINI MINIREG оставляет за собой право вносить изменения в представленную информацию без предварительного уведомления в связи с постоянным улучшением характеристик продукта.

The aim of this document is to provide useful information to the designer and/or installer. Upon consideration of the normal product evolution, FIORENTINI MINIREG S.p.A. is at any time free to modify data concerning the items presented. It is necessary to state that the photographs and the news concerning this catalogue are to be considered as general information only. Our TECHNICAL ASSISTANCE is available for further information concerning the exact definition of the product characteristics. Fiorentini Minireg reserves the right to make changes to this information without notification with the view of continuous improvement.

ОБОЗНАЧЕНИЯ:

Ps = Максимальное разрешенное давление
Pu = Давление на входе
Pu max = Максимальное давление на входе
Pd = Давление на выходе
Pd max = Разрешенное давление на выходе
Wd = Установленный диапазон значений
Wdo = Установленный диапазон значений OPSO
Wdu = Установленный диапазон значений UPSO
Bpu = Диапазон значений давления на входе
Pds = Установленное значение
AC/AG = Класс точности
SG = Класс давления закрытия
Q = Объемное значение расхода
C1 = Фактор формы корпуса
Cg = Коэффициент расхода

LEGEND:

Ps = Max allowable pressure
Pu = Inlet pressure
Pu max = Max inlet pressure
Pd = Outlet pressure
Pd max = Permissible outlet pressure
Wd = Set range
Wdo = Opso set range
Wdu = Upso set range
Bpu = Inlet pressure range
Pds = Set point
AC/AG = Accuracy class
SG = Lock up pressure class
Q = Volumetric flowrate
C1 = Body shape factor
Cg = Flow rate coefficient





АВИТОН

Официальный дистрибьютор
Pietro Fiorentini в России

**Адрес: 194100, Санкт-Петербург,
ул. Литовская, д.4, лит. А
Телефон/факс: 8 (812) 677-19-58
E-mail: post@aviton.info**